

Extruded Profile

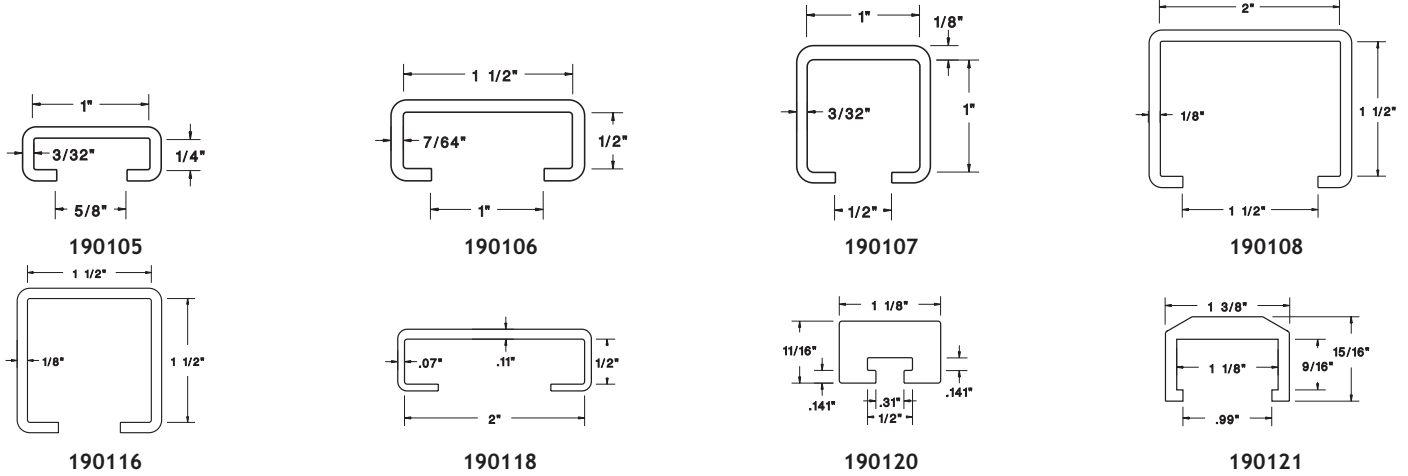

UHMW Rail Covers Available from stock in 10 or 20 ft. lengths



UHMW Snap-Ons Available from stock in 10 or 20 ft. lengths. Smaller sizes in coils.

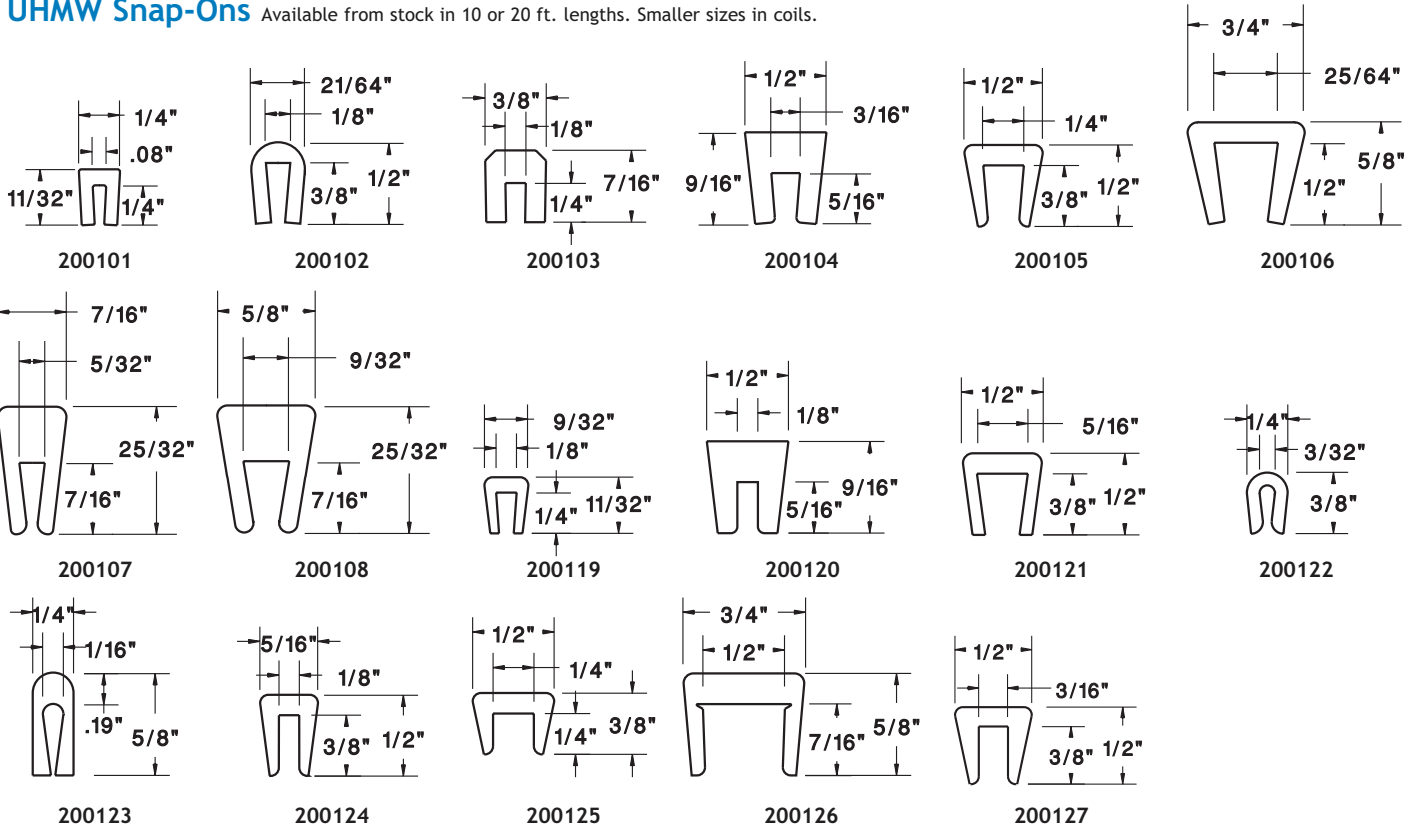

MD-Nylon Snap-Ons

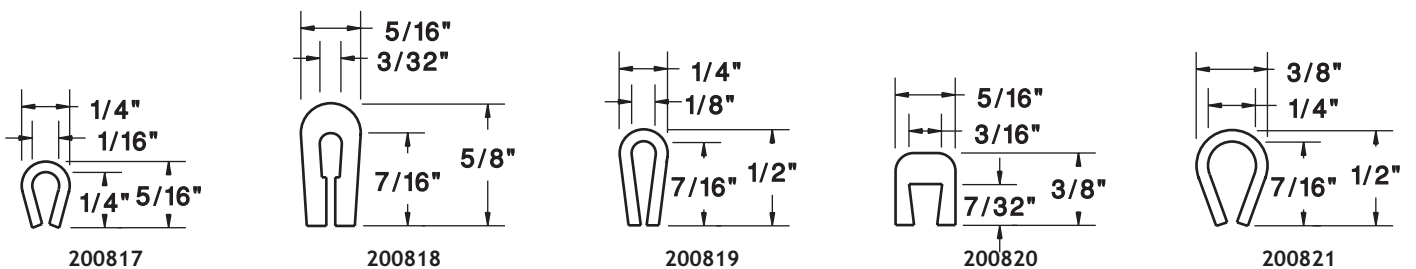



Nylon, UHMW and High-Temperature Extruded Profile

MD-Nylon J-LEG

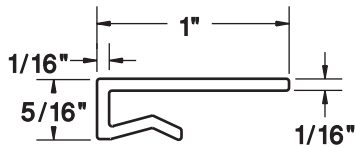

FOR 1/8" TO 3/16" RAIL
200118

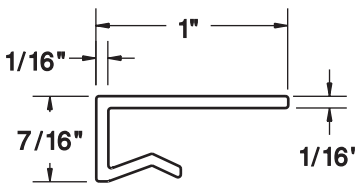

FOR 1/4" TO 5/16" RAIL
200117

UHMW J-LEG

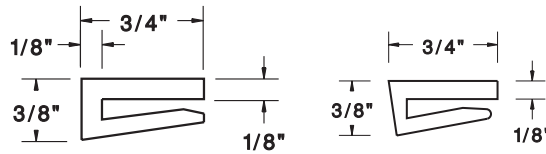

FOR 1/8" RAIL: 210116

OF/UHMW: 210334

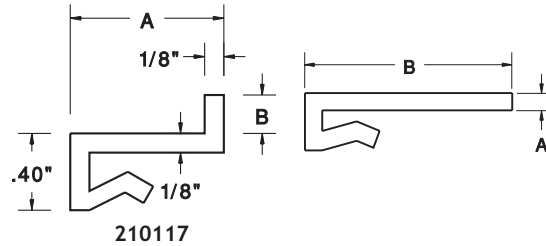

210117

Edge Guide J-Legs for 1/8" Thick Rail

Part No.	B	A
210117	1/8	0.96
210130	3/16	0.96
210131	5/16	0.96
210132	1/8	1.00
210133	3/16	1.00

UHMW J-Leg for 1/8" Thick Rail

Part No.	A	B
210121	1/8	3/4
210101	1/8	1
210102	1/8	1-1/2
210103	1/8	2
210118	3/16	3/4
210104	3/16	1
210119	3/16	1-1/2
210105	3/16	2
210120	3/16	2-1/2
210106	3/16	3
210107	1/4	1
210108	1/4	2
210109	1/4	3

UHMW Full Round

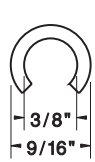

200110

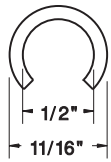

200111

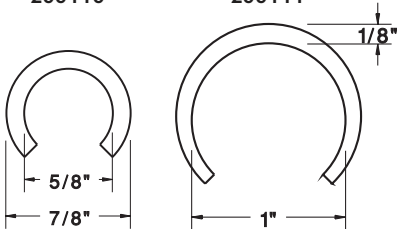

200112

200128

PTFE (Teflon®) High Temperature

PTFE profiles are available for use in applications where general purpose thermoplastic materials are unsuitable. Industries where PTFE guides and wear strips can be found include Bakeries, Food Processing, Chemical Processing and Glass Manufacturing.

The benefits of selecting PTFE are:

- Operating temperature of -350°F to 500°F
- Higher resistance to chemicals allows operation in harsh environments
- Very low coefficient of friction
- Excellent insulating properties for electrical applications
- Approved for direct food contact

UHMW Half Round

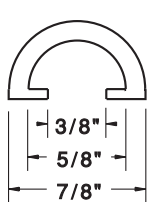

200113

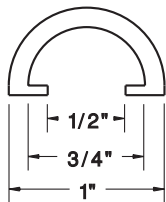

200114

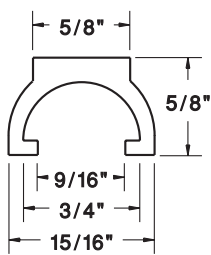

200115

Full Round Snap-On

Part No.	ID
201010	3/8
201011	1/2
201012	3/4
201028	1



Half Round Snap-On

Part No.	A	B	C
201023	11/16	1/2	1/4
201013	7/8	5/8	3/8
201014	1	3/4	1/2

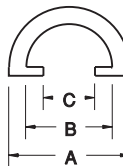

Bar Snap-On

Part No.	A	B	C	D
201019	9/32	11/32	1/8	1/4
201005	1/2	1/2	1/4	3/8
201006	3/4	5/8	3/8	1/2

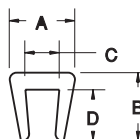

Other Standard Shapes

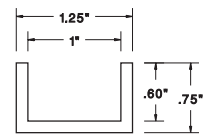

U-CHANNEL: 231021

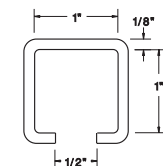

GUIDE RAIL: 191007

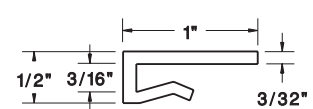

J-LEG: 211001

