

Custom Chain Guides, Belt Guides, and Profiles



Custom Chain Guides

Slideways manufactures chain guides for all roller chains including metric and multi-strand.

Materials of choice include:

- Oil-filled UHMW for high-speed applications
- Nyloil for heavy-duty applications
- Glass-filled Teflon for high temp or chemical resistance
- MD-Nylon for high load capacity
- Static-dissipative UHMW for electronics applications

There are many advantages to using custom-machined guides over extruded guides:

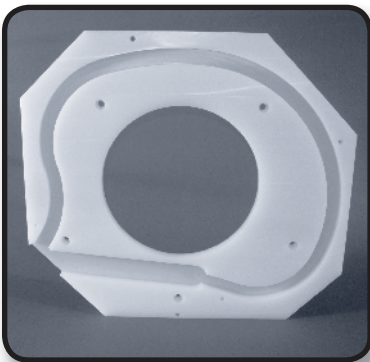

Machined Profiles

Usually no tooling
Short lead time

- 2 weeks or less

Tight Tolerances

- Machine to $\pm .005"$

Design flexibility

- Designs can change quickly
- Try new material

No minimum runs

versus

Extrusion

Tooling required
Long lead time

- 5-8 weeks for tooling

Loose tolerances

- Cooling rates cause warping

No design flexibility

- New tool required for revisions
- Minimum run required

Large minimum run

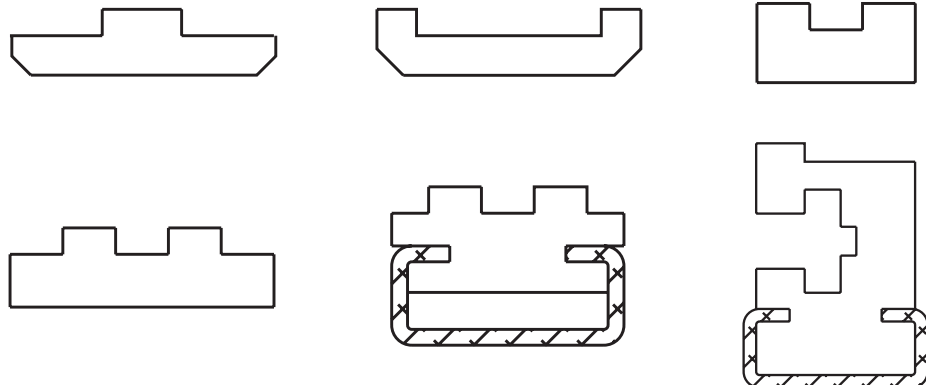

ROLLER CHAIN GUIDES FOR: #25, #35, #40, #40-2, #50, #50-2, #60, #60-2, #80, #80-2, #100, #120 AND METRIC SIZES