

ANSI Roller Chain Guides

More UHMW Grades

XX	Grade	Attribute*
02	Black Repro	Lower cost
03	Oil-Filled UHMW	Higher speed
25	Green Repro	Matches European guides
23	Static-Dissipative	Conductive
50	HT	Operates to 275°F

All of our Roller Chain Guides and Belt Guides are available in several grades of UHMW. To determine the correct part number, substitute the appropriate UHMW grade number wherever you see "XX" in the tables below.

*More details can be found in the UHMW Materials section on page 4.

Type TS

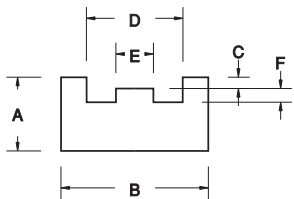

UHMW	More UHMW Grades	ANSI Chain No.	A	B	C	D	E	F
1601111	16XX111	35	0.39	0.79	.03	0.43	.15	.09
1601112	16XX112	40	0.39	0.98	.07	0.61	.25	.09
1601113	16XX113	50	0.59	1.18	.09	0.77	.30	.11
1601114	16XX114	60	0.59	1.38	.11	0.96	.40	.14
1601115	16XX115	80	0.79	1.57	.14	1.23	.50	.19
1601116	16XX116	100	0.98	1.97	.17	1.51	.59	.25
1601117	16XX117	120	1.18	2.36	.20	1.91	.80	.31

Type U

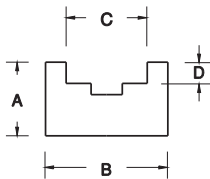

UHMW	More UHMW Grades	ANSI Chain No.	A	B	C	D
1601091	16XX091	35	.59	0.79	0.39	.15
1601092	16XX092	40	.59	0.79	0.51	.18
1601093	16XX093	50	.71	1.10	0.65	.24
1601094	16XX094	60	.71	1.10	0.78	.28
1601095	16XX095	80	.79	1.50	1.04	.30
1601096	16XX096	100	.98	1.57	1.30	.33
1601097	16XX097	120	.98	2.17	1.57	.39

Type T

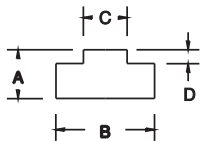

UHMW	More UHMW Grades	ANSI Chain No.	A	B	C	D
1601121	16XX121	35	0.59	0.78	.17	.10
1601122	16XX122	40	0.59	0.78	.29	.10
1601123	16XX123	50	0.59	0.78	.35	.12
1601124	16XX124	60	0.59	1.10	.47	.15
1601125	16XX125	80	0.71	1.34	.60	.18
1601126	16XX126	100	1.00	1.61	.72	.26
1601127	16XX127	120	1.25	2.01	.96	.31

Type TD

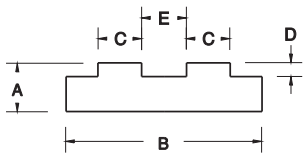

UHMW	More UHMW Grades	ANSI Chain No.	A	B	C	D	E
1601131	16XX131	35-2	.59	0.78	.17	.10	.23
1601132	16XX132	40-2	.59	0.85	.29	.10	.27
1601133	16XX133	50-2	.59	1.07	.35	.12	.37
1601134	16XX134	60-2	.59	1.34	.47	.15	.40
1601135	16XX135	80-2	.71	1.75	.60	.18	.55
1601136	16XX136	100-2	.79	2.09	.70	.25	.69
1601137	16XX137	120-2	.79	2.72	.93	.31	.86

Type K

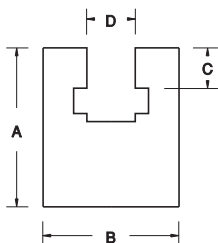

UHMW	More UHMW Grades	ANSI Chain No.	A	B	C	D
1601101	16XX101	35	0.88	0.78	.17	.22
1601102	16XX102	40	1.05	1.10	.29	.33
1601103	16XX103	50	1.43	1.50	.35	.42
1601104	16XX104	60	1.85	1.50	.47	.49
1601105	16XX105	80	1.77	1.57	.60	.66
1601106	16XX106	100	1.97	1.97	.70	.79
1601107	16XX107	120	2.36	2.36	.93	.92

More UHMW Grades

XX	Grade	Attribute*
02	Black Repro	Lower cost
03	Oil-Filled UHMW	Higher speed
25	Green Repro	Matches European guides
23	Static-Dissipative	Conductive
50	HT	Operates to 275°F

All of our Roller Chain Guides and Belt Guides are available in several grades of UHMW. To determine the correct part number, substitute the appropriate UHMW grade number wherever you see "XX" in the tables below.

*More details can be found in the UHMW Materials section on page 4.

Stainless and Galvanized Mounting Channel are sold separately. (See page 26)

Type CU—Mounted

UHMW	More UHMW Grades	ANSI Chain No.	A	B	C	D	E	Channel Size
1601061	16XX061	35	.59	0.78	0.39	.15	0.79	C3
1601062	16XX062	40	.59	0.78	0.51	.18	0.79	C3
1601063	16XX063	50	.71	1.10	0.67	.24	0.95	C5
1601064	16XX064	60	.71	1.10	0.78	.28	0.95	C5
1601065	16XX065	80	.79	1.50	1.04	.30	1.16	C9

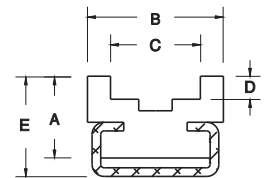

Type CT—Mounted

UHMW	More UHMW Grades	ANSI Chain No.	A	B	C	D	E	Channel Size
1601044	16XX044	40	.59	0.78	.29	.10	.79	C3
1601045	16XX045	50	.59	0.78	.35	.12	.79	C3
1601046	16XX046	60	.59	1.10	.46	.15	.79	C5
1601047	16XX047	80	.71	1.34	.60	.18	.95	C5

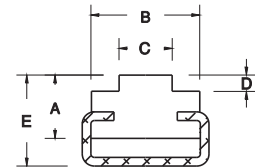

Type CTD—Mounted

UHMW	More UHMW Grades	ANSI Chain No.	A	B	C	D	E	Channel Size
1601048	16XX048	40-2	.59	0.85	.29	.10	.79	C3
1601049	16XX049	50-2	.59	1.06	.35	.12	.79	C5
1601050	16XX050	60-2	.59	1.34	.47	.15	.79	C5
1601051	16XX051	80-2	.71	1.75	.60	.18	.95	C9

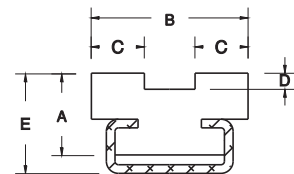

Type CTS—Mounted

UHMW	More UHMW Grades	ANSI Chain No.	A	B	C	D	E	Channel Size
1601071	16XX071	35	0.78	.03	0.43	0.15	0.09	C3
1601072	16XX072	40	0.98	.07	0.61	0.25	0.09	C3
1601073	16XX073	50	1.18	.09	0.77	0.30	0.11	C5
1601074	16XX074	60	1.38	.11	0.96	0.30	0.14	C5
1601075	16XX075	80	1.57	.14	1.23	0.50	0.19	C9

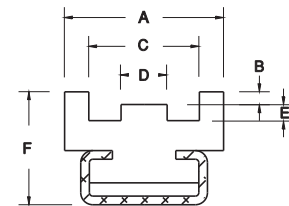

Type CKG—Mounted

UHMW	Other Materials	ANSI Chain No.	A	B	C	D	Channel Size
1601052	16XX052	35	1.18	.17	.22	0.94	C10
1601053	16XX053	40	1.18	.29	.33	0.94	C10
1601054	16XX054	50	1.18	.35	.42	0.94	C10
1601055	16XX055	60	1.77	.47	.49	1.58	C11
1601056	16XX056	80	1.77	.60	.65	1.58	C11

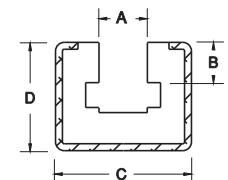

Type CK—Mounted

UHMW	Other Materials	ANSI Chain No.	A	B	C	D	E	Channel Size
1601081	16XX081	35	0.80	0.78	.17	.22	0.94	C3
1601082	16XX082	40	1.01	1.10	.29	.33	1.13	C5
1601083	16XX083	50	1.24	1.50	.35	.42	1.53	C9
1601084	16XX084	60	1.66	1.50	.47	.49	1.95	C9
1601085	16XX085	80	2.26	1.50	.60	.65	2.55	C9

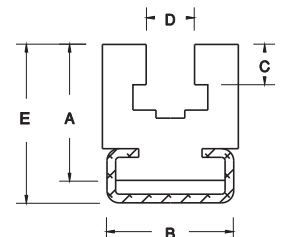

Extended Pitch Conveyor Chain Guides

More UHMW Grades

XX	Grade	Attribute*
02	Black Repro	Lower cost
03	Oil-Filled UHMW	Higher speed
25	Green Repro	Matches European guides
23	Static-Dissipative	Conductive
50	HT	Operates to 275°F

All of our Roller Chain Guides and Belt Guides are available in several grades of UHMW. To determine the correct part number, substitute the appropriate UHMW grade number wherever you see "XX" in the tables below.

*More details can be found in the UHMW Materials section on page 4.

Channel Style

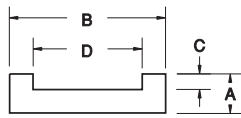

UHMW	More UHMW Grades	ANSI Chain No.	A	B	C	D
1601001	16XX001	2040	.31	1.25	.13	0.88
1601002	16XX002	2050	.38	1.25	.16	1.00
1601003	16XX003	2060	.38	1.50	.19	1.25
1601004	16XX004	2080	.50	2.00	.25	1.56
1601005	16XX005	2100	.63	2.25	.31	1.88
1601006	16XX006	2120	.63	2.75	.38	2.25

Raised Track

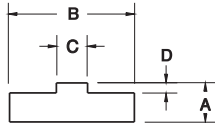

UHMW	More UHMW Grades	ANSI Chain No.	A	B	C	D
1601025	16XX025	2040	.31	1.00	.25	.08
1601026	16XX026	2050	.31	1.25	.31	.10
1601027	16XX027	2060	.31	1.25	.44	.12
1601028	16XX028	2080	.38	1.50	.56	.13
1601029	16XX029	2100	.50	2.00	.69	.21
1601030	16XX030	2120	.50	2.25	.94	.26

Channel with Raised Track

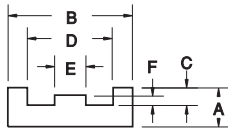

UHMW	More UHMW Grades	ANSI Chain No.	A	B	C	D	E	F
1601037	16XX037	2040	.31	1.00	.14	0.69	.25	.08
1601038	16XX038	2050	.38	1.25	.19	0.81	.31	.10
1601039	16XX039	2060	.50	1.50	.21	1.13	.44	.12
1601040	16XX040	2080	.50	2.00	.25	1.44	.56	.13

Mounting Channel

C3

Galv. 181606
SS 181706

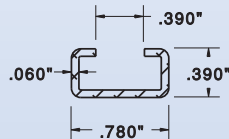

C10

Galv. 181609
SS 181709

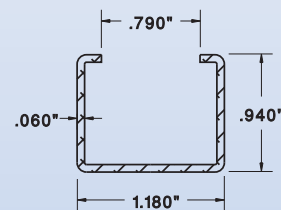

C5

Galv. 181607
SS 181707

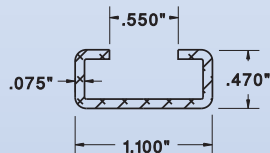

C11

Galv. 181610
SS 181710

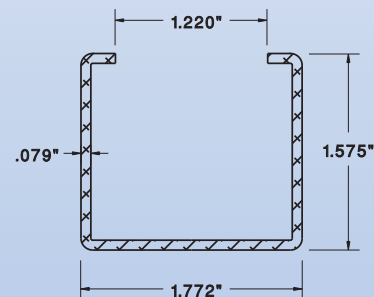

Custom Chain Guides

Slideways manufactures chain guides for all roller chains including metric and multi-strand.

Materials of choice include:

- Oil-filled UHMW for high-speed applications
- Nyloil for heavy-duty applications
- Glass-filled Teflon for high temp or chemical resistance
- MD-Nylon for high load capacity
- Static-dissipative UHMW for electronics applications

There are many advantages to using custom-machined guides over extruded guides:



Machined Profiles

- Usually no tooling
- Short lead time
 - 2 weeks or less
- Tight Tolerances
 - Machine to $\pm .005"$
- Design flexibility
 - Designs can change quickly
 - Try new material
- No minimum runs

versus

Extrusion

- Tooling required
- Long lead time
 - 5-8 weeks for tooling
- Loose tolerances
 - Cooling rates cause warping
- No design flexibility
 - New tool required for revisions
 - Minimum run required
- Large minimum run

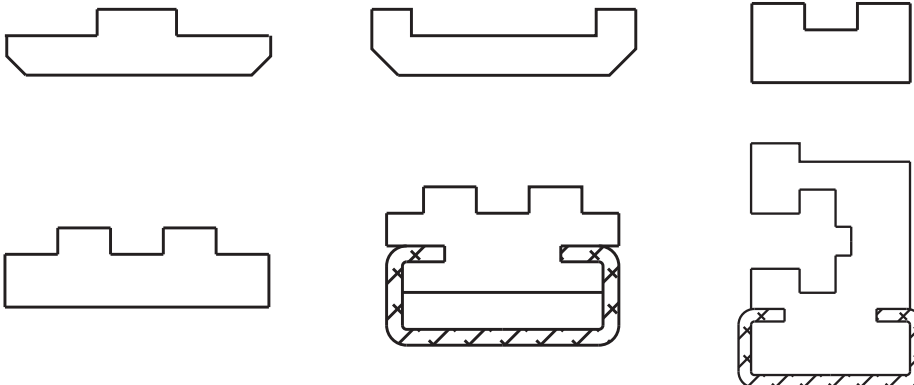
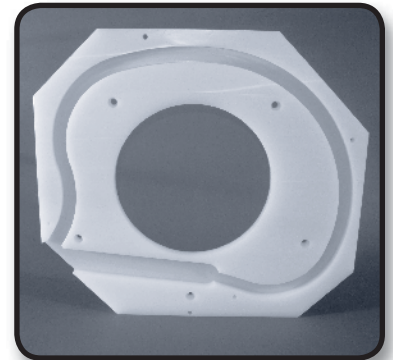

ROLLER CHAIN GUIDES FOR: #25, #35, #40, #40-2, #50, #50-2, #60, #60-2, #80, #80-2, #100, #120 AND METRIC SIZES